

Admiral 40

(B1100)(7580.02)(7580.35)

Admiral 38

(B1050)(7580.12/22)(7580.16/26)
(7580.15)

Training
Trouble Shooting
Adjustments



1	Remarks	5
2	General	7
	2.1 Settings	8
	2.2 Brief Description	11
	2.2.1 Switch Off Suction/Recovery Tank Filled Up	14
	2.2.2 Initial Position Of Machine/Release, Lock Functions	15
3	Check Settings For Machine Type, TSG And Options, Display And Delete Last Error	18
	3.1 Check And Set Machine Type	23
	3.2 Check And Set Options	24
	3.3 Check And Set TSG	25
	3.4 TSG Error 3211	28
	3.5 View And Delete Last Appeared Error In The Display	29
4	Programming Different Cleaning Function Procedures Depending On Accelerator Position (Check And Set)	30
	4.1 Programme Functions	32

5	Specific Customer Settings (Display Of Last Error And Selection Of Water Stage, Cleaning Agent, SWA, Side Brush, Filter) <i>PPV</i>	37
	5.1 PPV1	40
	5.2 PPV2	41
	5.3 PPV3	42
	5.4 PPV4	43
	5.5 PPV5 (B 1100 only)	44
	5.6 PPV6 (B 1100 only)	45
	5.7 PPV7 (B 1100 only)	46
	5.8 PPV8 (B 1100 only)	47
6	Setting Of Modules	48
	6.1 Module 1	49
	6.2 Module 3	50
7	Settings Of CAN Operator Panels (B 1100 only)	51
8	Water Pump	52
	8.1. Water Amounts	52
	8.2 Standstill Detection for Water Pump	54

9	Drive Controllers	55
9.1	SEVCON Controller (Diagnostic LED)	55
9.1.1	Signal Measurement On Controller (SEVCON)	58
9.2	ATECH / ZAPI Controller	63
9.2.1	Automatic Monitoring Of Components	65
9.2.2	Error Messages Displayed Via LED	66
9.2.3	Explanations For Displayed Error Messages	67
9.3	Drive Motor Hakomatic B1050 (Amer)	84
9.3.1	Tyre replacement	84
9.3.2	Check / replacement of carbon brushes	88
9.3.3	Diagnostic LED for drive control unit (Italsea)	89
10	Error Table With Information On Service Display	91
11	Notes	113
12	Brooms, Brushes & Blades	114

1. Remarks

This document is structured so as to allow and seek continuous extension. You thus receive the documents with the annotation that more or revised pages are to follow in future.

This decision has been taken to allow adding modifications made to the machine equally to the documents as revisions.

Beyond that this document may be improved upon your advice and proposals. I would thus be grateful to receiving your feedback.

1. Remarks

Caution :

- Before working at the machine, disconnect voltage supply (pull battery plug) except for the purpose of voltage and current measurement.
- When replacing stripe fuses, only loosen screws. Do not remove them completely - short-circuit hazard.
Make sure to fully and evenly insert new blade fuses under the screws.
- After each repair proceed to starting and service current measurement to allow detection of eventual defects.
- When working at the machine, comply with the general safety and accident prevention regulations as provided by law.

2. General

The Hakomatic B 1100 and the Hakomatic B1050 are equipped with a service indication in the hour meter display. Upon switching the key switch ON, a 4-digit code describing the software version (e.g. 3.018), is displayed for about 3 seconds, followed by another 4-digit code signalling the last error which again is followed by the hour meter indication. Upon launch of the Hakomatic B1050, software version has updated to 4.020. With the software revision 4.026 the Hakomatic B1100 TB 1230 was introduced.

As soon as a malfunction occurs, the red LED signalling a defect lights up and a warning buzzer sounds. The current error code appears (as 4-digit alpha-numeric code in the service display) with blinking dots between the digits. When all these criteria are met, the error is a current one!

There is NO error code, containing a “0”.

Find the error codes listed in a table in chapter 11.

This document uses the following abbreviations:

TSG - low discharge signal sender

SWA - dirty water recycling

2.1 Settings

Settings on the control electronics/panel which have to be set and checked on each machine:

In contrast to the Hakomatic B1100, scope of performance of the Hakomatic B1050 is reduced and does not feature all the options available in the Hakomatic B1100. The Hakomatic B1050PB (Plate Brush aggregate) has the side scrub unit optionally available only; the Hakomatic B1050CB (Cylindrical Brush aggregate) has the side broom unit optionally available, while the pre-sweeper, dirty water recycling and cleaning agent dosage (99756402) options are available and settable for the Hakomatic B1100 only. The B1050 PB 1230 doesn't have any options adjustable via the control modules of the machine control system.

The Hakomatic B1100 PB1230 is equipped with the pre-sweep unit generally.

- Machine type
- TSG (low discharge signal sender - also called LDS)
- Options
- Delete display of last error after repair
- Programme variants depending on the accelerator position

2.1 Settings

Settings which may be set via operator panel according to customer requirements:

- Display of last (remedied) error upon switching machine ON
- Selection of water stage upon start of cleaning
- Cleaning agent ON in addition to switching water ON (B1100 & B1100 PB 1230 only)
- Switching over to SWA upon switching water ON (B1100 only)
- Side brush additionally ON in addition to switching ON scrubbing (B1100 and B1050 PB only)
- Side broom additionally ON in addition to switching ON scrubbing (B1050CB)
- Filter shaking (B1100 only & B1100 PB 1230)
- Filter suction ON in addition to sweeping ON (B1100 only & B1100 PB 1230)
- Automatic filter shaking after sweeping (B1100 only & B1100 PB 1230)

2.1 Settings

Settings at Module 1:

- Dip-switch for electronic circuit-breakers

Settings at Module 3:

- Dip-switch for electronic circuit-breakers and module coding

Settings at the additional operator panels (ADM 40 only):

- Dip-switch for operator panel coding

2.2 Brief Description

Machine control is effectuated via the following electronics:

- Control electronics
- Module 1
- Module 3 (for pre-sweeper, side broom and side brush, 3rd brush options)
- Operator panel
- Cleaning agent dosage /SWA operator panel (B1100 only)
- Pre sweeper operator panel (B1100 only)
- Cleaning agent module (optional, B1100 only)
- Auxiliary voltage module (36V/24V transformer)

Voltage to the electronics is supplied by the auxiliary voltage module which transforms 36 Volts to 24 Volts. As the electronics are the same as integrated in the B910 and B 750R machines, the 24V electronics have to be transformed for use in the B 1100 and B1050 machines. Components such as the motors and pumps, however, are still 36V components.

The 24V voltage supply must not, even under load, fall below 23V since otherwise, supply of the modules 1 and 3 would be insufficient and cause a CAN error (4000 error code).

2.2 Brief Description

The control electronics covers all control and monitoring functions in the machine except for drive control.

Operation of drive controller is independent from the other electronics and only the release signal and the signal for speed reduction are transmitted via control electronics to drive controller. Beyond that, a signal is transmitted from drive controller to control electronics for forward and reverse ride.

Upon occurrence of a defect on the drive controller, an error code is not output since this controller has its own diagnostic indicator (see chapter 10).

The buttons for scrubbing, suction, scrubbing and suction and the green Hako button for combined cleaning may be switched arbitrarily such that the selected function is activated. Pre-sweeper/side broom and /or side brush function can be activated or de-activated disregarding of the selected cleaning mode, if present in the machine.

The remaining functional buttons (water, brush ground pressure) allow activating or de-activating the related functions in addition to the cleaning procedure without effect on the running function.

2.2 Brief Description

The machine is equipped with a seat switch. Activation of this switch is required before switching key switch on since otherwise sweeping and scrubbing functions (even in combination) are locked. If the seat switch is not activated, suction can only be activated for the „Hand suction hose“ option.

A reset of the machine after it was deactivated by the seat contact switch, is realized by switching off and on again with the key switch.

Constant activation of the seat switch is also required. Leaving the seat while key switch is ON causes locking of the functions.

The seat contact switch is 3 seconds delayed.

At the Hakomatic B1050 machines the sequence of switching on the machine (key switch, seat contact switch), has no influence to the ability of function of the machine.

It is equally required to release parking brake to enable cleaning functions and drive control is released.

To switch on the “TOOL”-function of the B1050 machines, it is necessary to activate the brake of the machine.

2.2.1 Switch Off Suction / Recovery Tank Filled Up

The suction function is either stopped by the operator via button actuation or automatically upon the „recovery tank filled up“ signal.

Switching off by operator:

- Squeegee is lifted up
- Suction motors switch off delayed (15 seconds)

Switching off after tank filled up:

- The switch signalling „recovery tank filled up“ opens as soon as the tank is filled
- If switch is open for 3 seconds or longer (spill protection) squeegee will be lifted and the suction motors switch off with a delay of 15 seconds.

2.2.2 Initial Position/Release, Lock Functions

When turned ON and the seat switch closed, all units of the machine are set to „initial position“.

This means that the control electronic triggers all units (lifting elements and motors). Lifting elements will be lifting up as long as they are not switched off by the micro-switch controlling the upper limit position and integrated in the lifting element.

This means that the outputs for the lifting elements are powered for approx. 6 sec every time the machine is switched on. During this time a voltage can be measured at the outputs for the lifting elements.

Motors are off and the cleaning unit LED indication in the operator panel extinguishes. The drive controller is transmitted the release signal.

Should the seat switch not be activated, the motors will also be turned off - for safety reasons - but the lifting elements will not be lifting and the travel drive controller will not be released either.

The only exception: water suction by hand hose (B1100).

2.2.2 Initial Position/Release, Lock Functions

Before operation of the pre-sweeper (B1100 & B1100 PB 1230 only), the hood is to be closed and the dirt hopper correctly inserted. The hood and the dirt hopper are monitored each by a switch (NC switch) being serially connected. As soon as the switch opens, the LED in the standard operator panel lights to signal „open hood“ and the pre-sweeper function is disabled. Since both switches are serially connected, this LED equally lights if the switch signalling „no dirt hopper inserted“ opens. In case of faulty function, check the switch and all cable connections and connectors. Another safety request is effected by the thermal switch of the broom motor. If this switch opens, the pre-sweeper function will be disabled and an error code appears.

After engaging the parking brake, all cleaning functions will be disabled and the red LED „brake engaged“ lights. This switch is an NC switch as well and it is thus required, in case of faulty function, to check the switch, all cable connections and connectors.

2.2.2 Initial Position/Release, Lock Functions

Activation of the „Brushes“ function causes lowering of the brush head to the so-called central position. The lifting element does not attain the lower limit position before cleaning with increased ground pressure. The brush head lifting element thus has 3 micro-switches integrated, one each for the upper, the central and the lower limit position.

Extracting the side brush unit is possible only after the brush head had lowered or in other words: if the central position micro-switch does not switch, the „brush lowering completed“ signal is missing and the side brush does not swing out. This signal depends on the central position micro-switch only such that swinging out of side brush is possible as well for cleaning with increased brush ground pressure. Since on its way down to the lower limit position the central position micro-switch had been triggered even if no fault occurred during cleaning with increased ground pressure.

3. Machine Type Settings

Check settings for machine type, TSG and options; display and delete last error

The settings described in this step are to be checked and modified if required. Proceed to check and adjustment in particular after electronics replacement.

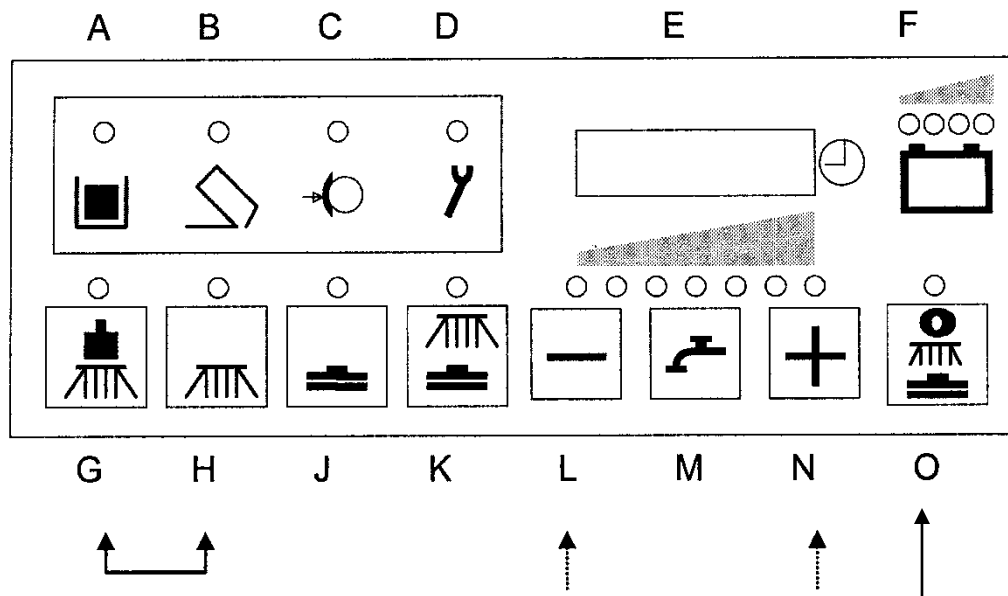

3. Machine Type Settings

The picture shows the Hakomatic B1050 operator panel. Position of the programming buttons is identical to those of the Hakomatic B1100. Only the icons differ due to the different functional scope of this machine.

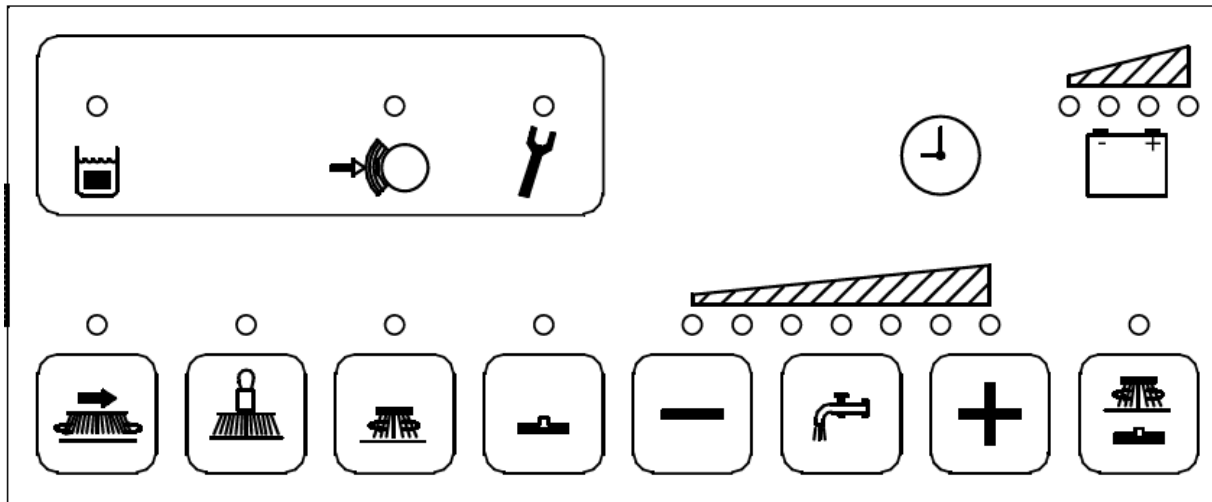

B1050 PB & CB & PB 1230

3. Machine Type Settings

Entry into programming

1. Switch off machine by key switch
2. Simultaneously press "G" and "H" and hold depressed, then switch on key switch
3. Hold depressed both buttons as long as the software version is displayed then release buttons

Display of set machine type then appears automatically. Use the "N" button to proceed to display of set options and display of TSG setting or then to display of last (remedied) error. Use the "L" button to return to previous display. Quit programme any time by switching OFF the key switch.

3. Machine Type Settings

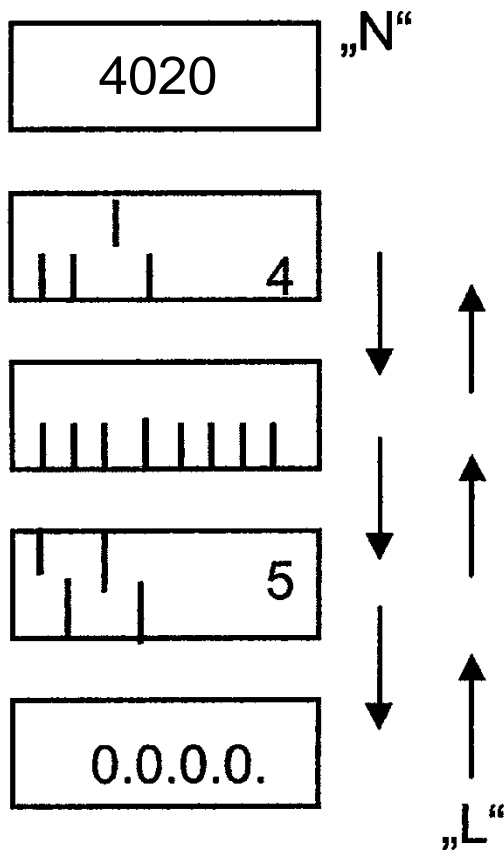

Software version, automatic change to next display

Set machine: 4 means B 1100; 11 means B 1050
13 means B1050 PB 1230;
14 means B1100 PB 1230

Set options

TSG setting

Display last error and reset

3. Machine Type Settings

Control electronics

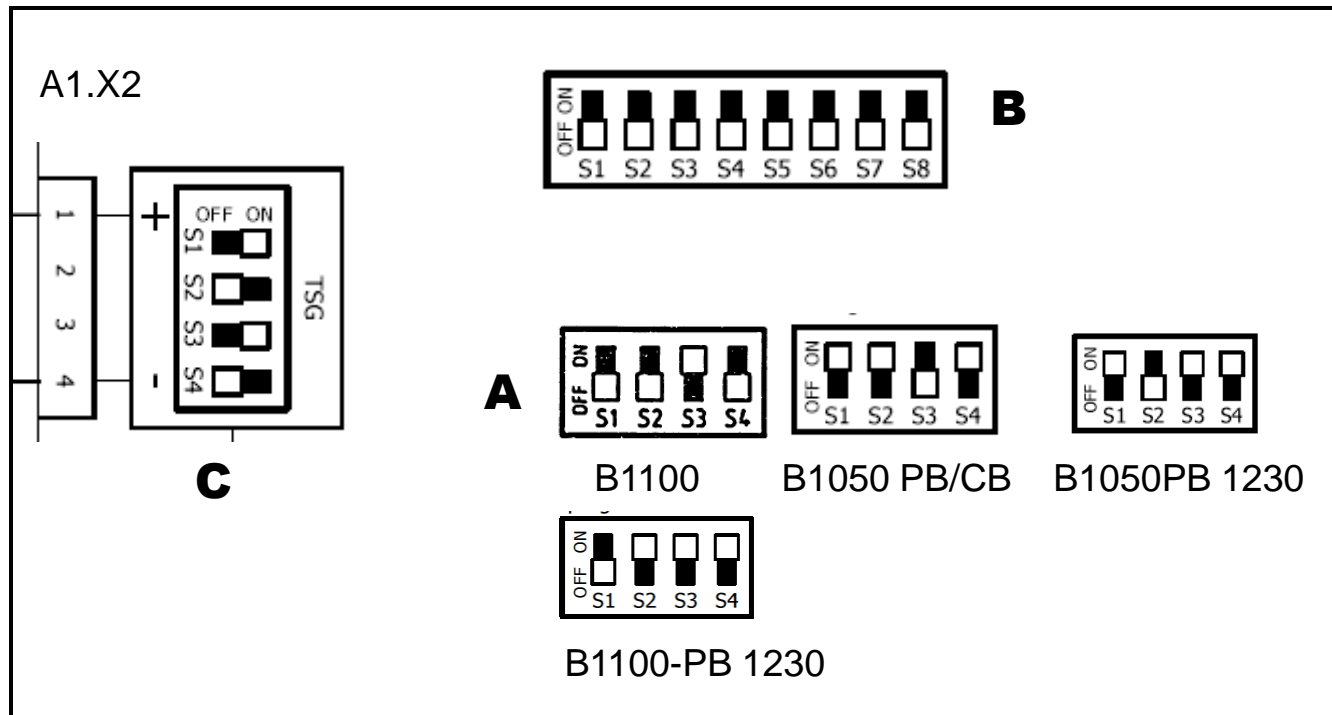

3.1 Check And Set Machine Type

1. Make sure to have the correct machine type set. Use the Dip switch A on the control electronics for setting (see Page 22)
2. For the B1100 machine, the bars no. 1, 2, 4 are to set in bottom and the bar no. 3 in top position. This setting is a prerequisite for display of the cipher 4.
For the B1100 PB1230 machine, the bars no. 2, 3, 4 are to set in top and the bar 1 in bottom position. This setting is a prerequisite for display of the cipher 14.
For the B1050 machine, the bar no. 3 is to set in bottom and the bars 1, 2 and 4 in top position. This setting is a prerequisite for display of the cipher 11.
For the B1050 TB 1230 machine, the bar no. 2 is to set in bottom and the bars 1, 3 and 4 in top position. This setting is a prerequisite for display of the cipher 13.
3. If other ciphers appear, modify combination at the Dip switch.

B 1100	1: OFF	B 1100	1: OFF	B 1050	1: ON	B 1050	1: ON
ADM 40	2: OFF	PB1230	2: ON	ADM 38	2: ON	PB 1230	2: OFF
	3: ON		3: ON		3: OFF		3: ON
	4: OFF		4: ON		4: ON		4: ON

3.2 Check And Set Options

1. Setting each option in the machine is required at the Dip switch B (see p. 22) on the control electronics.
2. The Dip switches are assigned as follows:

1:	Cleaning agent dosage (B1100 & B1100PB 1230)	(set = "ON")
2:	SWA (B1100 only)	(set = "ON")
3:	Side brush (B1100 & B1050PB)	(set = "ON")
4:	Tool (B1100 suction only)	(set to "OFF")
	Tool (B1100 PB1230 & B1050PB / CB and B1050 PB 1230 Spraying and suction)	(set = "ON")
5:	Pre-sweeper (B1100 & B1050CB* and B1100PB1230)	(set = "ON")
6:	Cylindrical brush deck (B1050 only)	(set = "ON")
7 - 8:	not assigned, i.e. "OFF"	

* - for the B1050CB the side broom is activated.

3. An option is set if the Dip switch is set to ON.

3.3 Check And Set TSG

1. The TSG has to be set in any case to the correct battery type.
2. When fitting other battery types, modify TSG setting as described below by using Dip switch C on the control electronics (see p. 22)
3. Dip switch 4 is to set to 36 V (OFF).

Set the TSG according to the following table. (No. 1 GIS(USA) - is the default setting)

	6	7	5	4	3	2	1	0
→	Gel (Sonnenschein)	Gel (Deta)	PzS	PzS fremd	GIS	GIS fremd	GIS USA	GIS USA
1	0	1	1	0	1	0	1	0
2	1	1	0	0	1	1	0	0
3	1	1	1	1	0	0	0	0
4	ON = 24V / OFF = 36V							

3.3 Check And Set TSG

“1” means ON; “0” means OFF

The addition “foreign” indicates batteries which are not delivered by Hako.

Reset voltage for the TSG: approx. 38.5V.

This voltage is required to reset the TSG capacity to 100%.

Caution: as far as maintenance-free gel batteries are concerned, the difference between Sonnenschein and Deta is no longer made and setting depends on the battery type. Setting 6 for GIV batteries and setting 7 for PzV batteries, irrespective of the manufacturer. (For historical reasons, the designations Sonnenschein and Deta remain in the documents).

The adjustments 0 and 1 (GiS USA) are for the use with US manufactured batteries only.

3.3 Check And Set TSG

GiS and GiV are Grid plate batteries,

PzS and PzV are Tubular plate batteries,

GiV and PzV are maintenance free batteries
in Gel-Technologie,

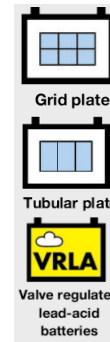

GiS and PzS are vented, low maintenance batteries with liquid electrolyte.

For block batteries the following short terms are also used:

GiS = FF

GiV = GF-Y; GF-V

PzS = FT

Trough batteries are available as following types:

EPzS and EPzV

3.4 TSG Error 3211

TSG - Remarks on the error 3211

The controller receives data from the TSG module in serial form and transmission of a telegram takes one second. The 3211 error occurs when two telegrams with the same contents are not received within 5 seconds and this equally is the case if there is no transmission at all.

Apart from an actual defect of the TSG the following causes are possible for this error message:

- No voltage supplied to the TSG (MK controller: A1:X2.1 + 4)
- TSG is in auto test mode: battery DIP switch set to off-off-off or on-off-off (1-2-3) - from Software revision 4.020 on, this adjustments are used for US-American batteries

After occurrence of the 3211 error it is also possible to use the LED of the TSG to detect functioning of data transmission since the TSG bar lights as soon as two telegrams with the same contents have been successfully transmitted within 5 seconds. In all other cases, the bar does not light.

3.5 View And Delete Last Error

View

1. Press “N” button three times; then a 4-digit error code with blinking dots appears (last error occurred and remedied)
2. Quit programme by switching OFF key switch (do not switch OFF key switch when proceeding to point “Delete”)

Delete

1. Press “O” button and hold depressed as long as the display changes to 0.0.0.0.
2. Release button, switch key switch OFF and on again
3. The software version appears then and changes to normal hour meter display
4. It is possible at any time and as described under “View” to read out the last occurred error from the memory and view it since the error code is saved there
5. Quit programme by switching OFF key switch

4. Programming Different Procedures

Programming of different procedures of cleaning functions depending on the direction switch (check and set)
(For setting of the B 1050 (ADM38), it is the position of buttons which is decisive and not the icon on the operator panel)

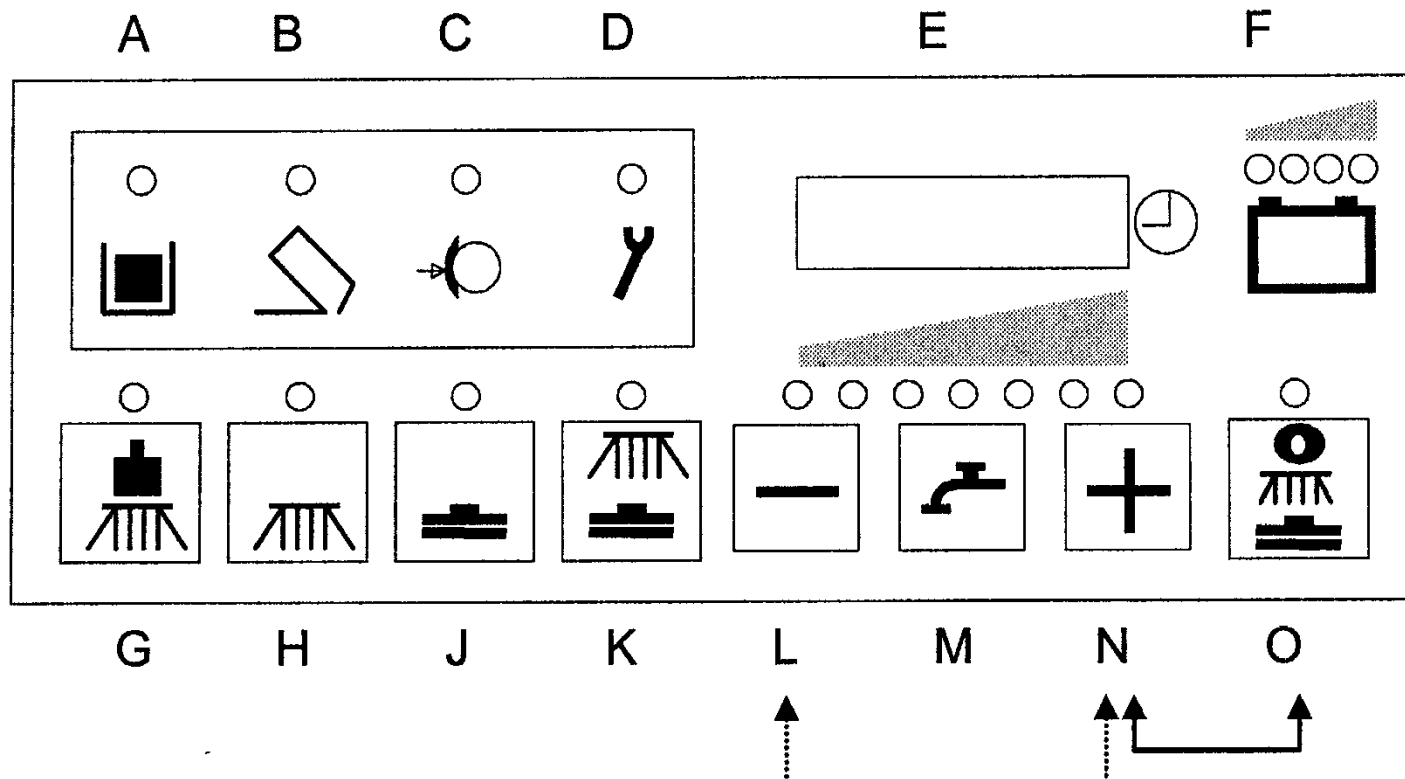

4. Programming Different Procedures

Check

1. Switch off machine by key switch
2. Simultaneously press "N" and "O" buttons and hold depressed, then switch on key switch
3. Hold both buttons depressed as long as the software version appears in the display then release both buttons
4. Viewing the different programmes is possible by pressing the button "L" (down) or the button "N" (up).
5. The active programme is marked by a dash in front of the cipher
6. Quit programme by switching OFF key switch (do not switch OFF key switch when proceeding to point "Set")

Set

1. Use the "L" or "N" button to select the desired programme
2. Press the "O" button and hold depressed until the dash appears in front of the cipher. The programme then is saved and active
3. Quit programme by switching OFF key switch

4.1 Program Functions

Precondition for functioning of the following programmes is that “Brushes” and/or “Suction” and/or “Sweep” are ON. All programmes allow normal cleaning and suction in ‘forward’ accelerator position; for the 'Neutral' and 'Reverse' accelerator positions, however, differences apply and are listed in the following table.

Programme code	Accelerator position/ Direction switch	Function according to accelerator position/direction switch		
		Brush head + Water	Squeegee	Broom (B1100 only)
1	Neutral	Brushes and water ON	Suction remains ON	Broom remains ON
	Reverse	Brushes and water ON	Lift squeegee	Broom remains ON

4.1 Program Functions

Programme code	Accelerator position/ Direction switch	Function according to accelerator position/direction switch		
		Brush head + Water	Squeegee	Broom (B1100 only)
2	Neutral	Brushes and water ON	Lift squeegee	Broom remains ON
	Reverse	Brushes and water ON	Lift squeegee	Broom remains ON
3	Neutral	Brushes and water OFF	Suction remains ON	Broom remains ON
	Reverse	Brushes and water ON	Lift squeegee	Broom remains ON

4.1 Program Functions

Programme code	Accelerator position/ Direction switch	Function according to accelerator position/direction switch		
		Brush head + Water	Squeegee	Broom (B1100 only)
4	Neutral	Brushes and water OFF, lift brush head	Lift squeegee	Broom off and lifted up
	Reverse	Brushes and water OFF, lift brush head	Lift squeegee	Broom off and lifted up
5	Neutral	Brushes and water OFF	Lift squeegee	Broom remains ON
	Reverse	Brushes and water ON	Lift squeegee	Broom remains ON

4.1 Program Functions

Programme code	Accelerator position/ Direction switch	Function according to accelerator position/direction switch		
		Brush head + Water	Squeegee	Broom (B1100 only)
6 (B 1100 only) & B1100 PB 1230)	Neutral	Brushes and water OFF, (delay of 1 second for brushes to avoid the brushes from being switched OFF when changing from forward to reverse ride)	Lift squeegee	Broom OFF and lifted up
	Reverse	Brushes and water ON	Lift squeegee	Broom OFF and lifted up

4.1 Program Functions

When the selected function of water supply, brush or suction function or the green Hakomatic button is switched off by changed accelerator position, the function-related LED blinks.

“ON” always means ‘switched ON’ and ‘lowered‘.

“OFF” only means ‘switched OFF’, ‘lifted’ is additionally indicated

5. Specific Customer Settings

(Display of last error and selection of water stage, cleaning agent, SWA, side brush, filter)

The settings described in this step can be modified according to customer requirements. Factory settings need not be adopted. For setting of the B 1050 (ADM38), it is the position of buttons which is decisive and not the icon on the operator panel.

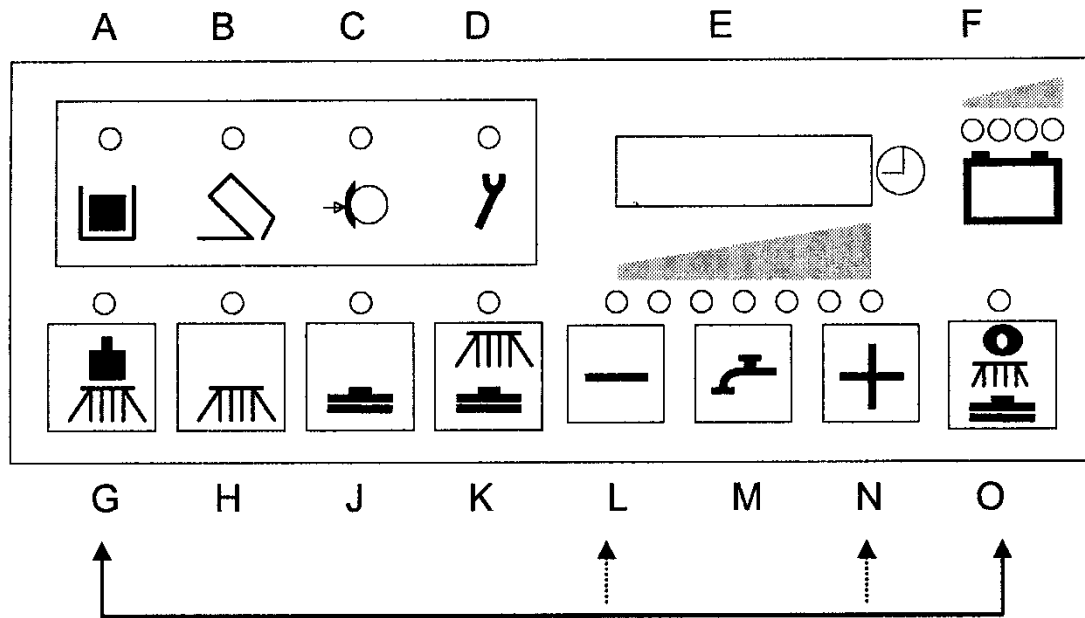

5. Specific Customer Settings

Entry into programming

1. Switch off machine by key switch
2. Simultaneously press "G" and "O" buttons and hold depressed, then switch on key switch
3. Hold both buttons depressed as long as the software version appears in the display, then release both buttons

Then the programmed settings for the following points are displayed automatically:

- Display of last (remedied) error upon switching ON: yes / no
- Water stage at start of cleaning: last selected stage/ always medium stage
- Switch on cleaning agent together with switching ON water: yes / no (B 1100 & B1100 PB1230)
Water stage for Scrubbing and suction: last selected stage/ always medium stage (B1050PB / B1050CB / B1050 PB 1230)
- Switch over to SWA upon water ON: clear water / SWA (B 1100 only)
Switch on side brush/side broom together with switching ON scrubbing: yes / no (B1050PB/CB)
- Switch on side brush together with switching ON scrubbing: yes / no (B 1100 only)
- Filter shaking: in interval / as long as button is depressed (B 1100 & B1100 PB 1230)
- Switch on filter suction together with switching ON sweeping: yes / no (B 1100 & B1100 PB 1230)
- Automatic filter shaking after sweeping: yes / no (B 1100 & B1100 PB 1230)

5. Specific Customer Settings

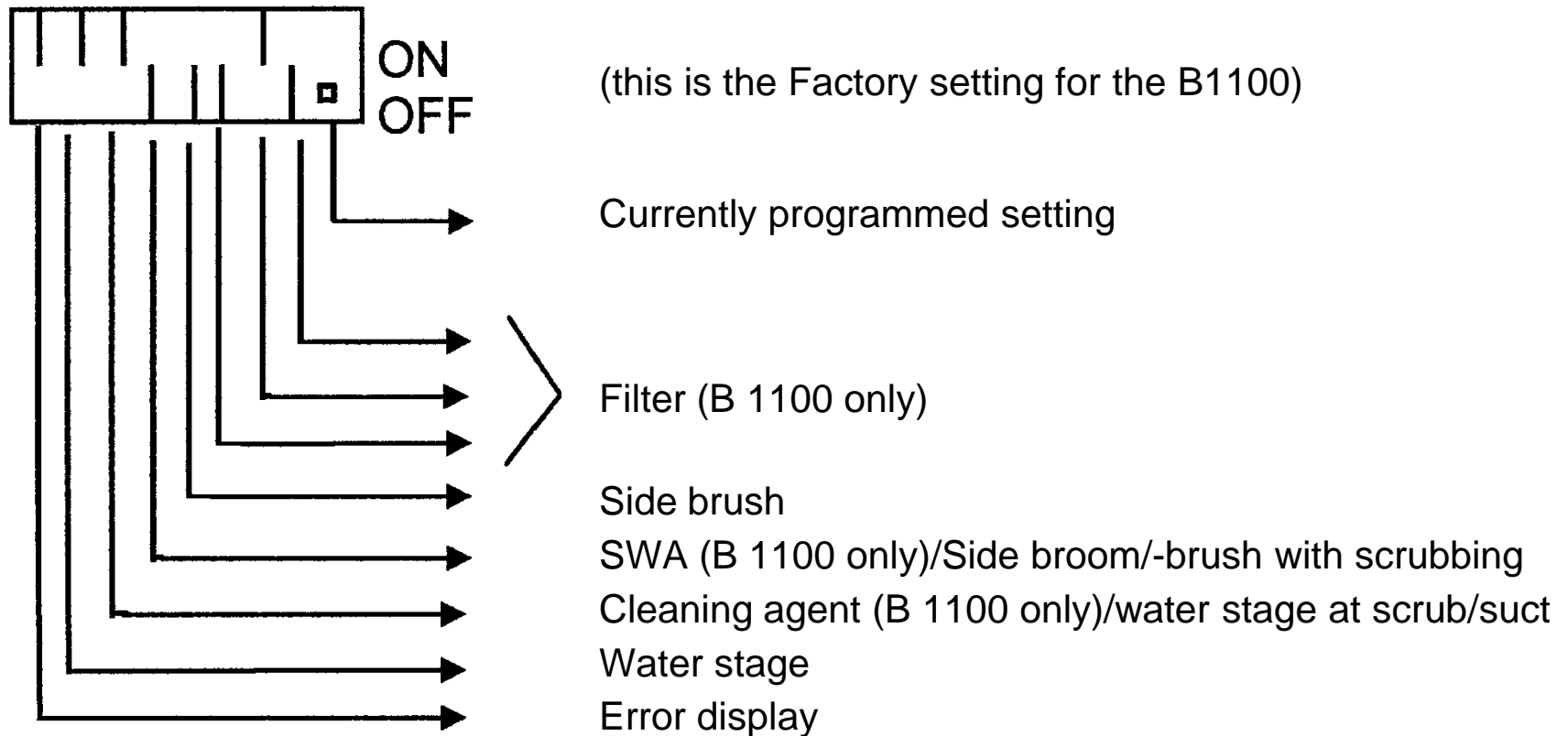

5.1 PPV1 (Display Of Last Error)

1. Select desired setting by “L” and “N” buttons
2. The corresponding bar starts blinking
3. Use “M” button to move the bar up and down
Up = ON = Error code (of the remedied error) will be displayed for 3 seconds
after switching on
Down = OFF = Error code (of the remedied error) will not be displayed
4. Save setting by pressing the green button (“O” button) as long as the dot appears
at the bottom right of the display

5.2 PPV2 (Water stage Upon Start of cleaning)

1. Select desired setting by “L” and “N” buttons
2. The corresponding bar starts blinking
3. Use “M” button to move the bar up and down
Up = ON = last selected stage is set
Down = OFF = always the medium stage is set
4. Save setting by pressing the green button (“O” button) as long as the dot appears at the bottom right of the display

5.5 PPV5 (Side Brush Upon Switching On Scrubbing) (ADM40) (B1100 only)

1. Select desired setting by “L” and “N” buttons
2. The corresponding bar starts blinking
3. Use “M” button to move the bar up and down
Up = ON = side brush is equally switched on
Down = OFF = side brush is not switched on
4. Save setting by pressing the green button (“O” button) as long as the dot appears at the bottom right of the display

5.6 PPV6 (Filter Shaking)

(B 1100 & B1100 PB 1230)

(ADM40)

1. Select desired setting by “L” and “N” buttons
2. The corresponding bar starts blinking
3. Use “M” button to move the bar up and down
Up = ON = Filter shaking as long as button is depressed
Down = OFF = Filter shaking after switching on by button 3 times in intervals
4. Save setting by pressing the green button (“O” button) as long as the dot appears at the bottom right of the display

5.7 PPV7 (Filter Suction Upon Switching On Sweeping

PowerBoss[®]
The Power of Clean

(B 1100 & B1100 PB 1230)(ADM40)

1. Select desired setting by “L” and “N” buttons
2. The corresponding bar starts blinking
3. Use “M” button to move the bar up and down
Up = ON = Filter suction is equally switched on
Down = OFF = Filter suction is not switched on
4. Save setting by pressing the green button (“O” button) as long as the dot appears at the bottom right of the display

(Auto Filter Shaking After Sweeping)

(B 1100 & B1100 PB 1230) (ADM40)

1. Select desired setting by “L” and “N” buttons
2. The corresponding bar starts blinking
3. Use “M” button to move the bar up and down
Up = ON = after a minimum of 2 minutes of sweeping, shaking is automatically switched on upon end of sweeping
Down = OFF = shaking is not automatically switched on upon end of sweeping
4. Save setting by pressing the green button (“O” button) as long as the dot appears at the bottom right of the display

6. Settings On Module

The settings on the modules have an influence on load values of the electronic circuit-breakers and the module coding.

6.1 Module 1

As they have an influence on the load value of the electronic circuit breakers for the brush head and squeegee lifting elements, the Dip switch settings have to be correct on Module 1.

Dip switch setting:

1: OFF

2: OFF

Circuit-breaker values:

Brush head: 5.7 A

Squeegee: 5.7 A

6.2 Module 3

As they have an influence on the module coding and the load value of the electronic circuit breakers for the pre-sweeper / side broom / side brush lifting elements, the Dip switch settings have to be correct on Module 3.

Modul 3 Code A (pre-sweeper B 1100 &):
(B 1100 PB 1230)
(Side broom B 1050 CB only)

1: OFF
2: OFF
3: OFF
4: OFF
electr. C-b.: 5.7 A

Modul 3 Code C (3rd Brush):
(B 1050 TB 1230 & B1100 PB 1230)

1: OFF
2: ON
3: OFF
4: OFF
electr. C-b: not required

Modul 3 Code D (Side brush):
(B1100 und B 1050 TB)

1: ON
2: ON
3: OFF
4: ON
electr. C-b: 1.9 A

7. Operator Panel Settings (B 1100 only) (ADM40)

The Code A and B operator panels (pre-sweeper / side brush and Cleaning agent / SWA) have to be correctly set - i.e. coded - on the Dip switch.

These operator panel are available only in the Hakomatic B1100 & B1100 PB 1230. They are located under the right-hand operator panel of the machine.

Code A (Pre-sweeper/Side brush; A2):

1: OFF

2: OFF

Code B (Cleaning agent / SWA; A10):

1: ON

2: OFF

8. Water Pump

8.1 Water Amounts

For checking function of the water pump, voltage for each of the stages can be measured at Module 1 (A5:X2:6+7).

When using a True RMS device, having water in the tank and ensuring that suction turbine is OFF, the values from the following table shall be obtained:

When using other than the indicated measuring devices, values may vary since measured voltage is pulsed. Beyond that the value depends on battery voltage. Here, measurement was done with charged battery presenting three green LED lighting in the battery indication.

The voltage values in the table are given for the Hakomatic B1100 and B1050PB only.

Beyond that, evaluation of the actually delivered water amount is to be preferred since voltage values only indicate whether water pump control is operable or not.

8. Water Pump

	Hakomatic B1100 / B1050PB		Hakomatic B1050CB	Option Tool Hakomatic B1050	
	without Sidebrush	with Sidebrush			
Stage 1:	xx V	ca. 1,3 l/min	ca. 2,7 l/min	ca. 1,3 l/min	ca. 1,0 l/min
Stage 2:	ca. 5,7 V	ca. 2,2 l/min	ca. 3,3 l/min	ca. 2,2 l/min	ca. 1,0 l/min
Stage 3:	ca. 7,4 V	ca. 2,9 l/min	ca. 3,9 l/min	ca. 2,9 l/min	ca. 1,0 l/min
Stage 4:	ca. 8,9 V	ca. 3,6 l/min	ca. 4,4 l/min	ca. 3,6 l/min	ca. 1,0 l/min
Stage 5:	ca. 12,0 V	ca. 4,7 l/min	ca. 5,5 l/min	ca. 3,9 l/min	ca. 1,0 l/min
Stage 6:	ca. 14,7 V	ca. 5,7 l/min	ca. 6,4 l/min	ca. 4,1 l/min	ca. 1,0 l/min
Stage 7:	ca. 20,0 V	ca. 7,5 l/min	ca. 8,2 l/min	ca. 4,4 l/min	ca. 1,0 l/min

8.2 Standstill Detection For Water Pump

Automatic standstill detection for water pump:

The electronics offer a possibility for water pump protection if delivery of pump is blocked.

When the pump takes in water from the tank but cannot deliver it to the brushes, a pressure builds up downstream the pump. Without protection by the electronics, the pump would continue delivery against this pressure and could be damaged.

The electronics detects interruption of free delivery of the pump and automatically switches off the pump for 2 seconds.

After these 2 seconds, pump is briefly switched on with simultaneous measurement whether delivery then is free or whether water supply to brushes is still blocked.

When delivery of the pump is free, the selected stage remains ON; if counter-pressure is still present, the pump again is switched OFF for 2 seconds. This procedure is repeated until fault will be remedied.

9. Drive Controller

9.1 SEVCON Controller (Diagnostic LED)

The light-emitting diodes (LED) are directly located on the electronics

LED indication	Malfunction	Remark
OFF	Drive controller without function	Voltage supply interrupted Check fuses and wiring
ON	Drive controller is operable	Drive controller function okay
2 signals	Wrong start sequence	Check accelerator and direction switch as well as cabling
3 signals	Output transistors do not connect or no connection to drive motor	Check wiring to drive motor; check carbon brushes; if okay but error still present replace drive controller

9.1 SEVCON Controller

LED indication	Malfunction	Remark
4 signals	Output transistors do not connect or no connection to drive motor	Check wiring to drive motor and drive motor. Check direction switch and direction contactors on drive controller; if okay but signals still present, replace drive controller
5 signals	Output transistors defective	160 A fuse blown, check release signal from control electronic; Check direction switch and direction contactors on drive controller; if okay but signals still present, replace replace drive controller

9.1 SEVCON Controller

LED indication	Malfunction	Remark
6 signals	Accelerator or cable connection interrupted	Check accelerator and wiring, plugged connection eventually loose; check direction switch and drive potentiometer switch
7 signals	Battery voltage insufficient, less than 13 Volts	Measure voltage, check connections
8 signals	Temperature of drive electronics exceeded (70 °C and higher)	Is travel drive smooth? Is parking brake setting okay? Longer uphill rides? Max. operating current approx. 45 A

9.1.1 Signal Measurement at the Drive Controller (SEVCON)

During test of the drive controller, the following points should be checked since faultless operation of the drive controller is not possible without the described signals applying accordingly.

The drive controller is designated by A6 in the circuit diagram and is supplied with 36 V even though some of the signals are 24-Volts signals.

The drive controller is a pulse controller activating the motor by the pulsed voltage. In case of full throttle forward ride, battery voltage always applies at the motor.

1. Is F51-160A fuse okay?
2. Is battery voltage applying at drive controller?
3. Is battery minus connected at drive controller?
4. Is battery voltage applying at A6-X51:2 after switching key switch ON?

9.1.1 Signal Measurement at the Drive Controller (SEVCON) **PowerBoss**[®] The Power of Clean

5. Cabling between accelerator potentiometer and drive controller okay?

Voltage measurement:

Green at A6-X51:8 (approx. 8.6V)

Red at A6-X51:9 (0-5V depending on potentiometer position)

Yellow at A6-X51:3 (approx. 0V)

Measured to battery minus

Resistance measurement (with machine switched off and potentiometer disconnected):

Between green and red: approx. 5.7 k Ω Reducing to approx. 1.8 k Ω upon actuation

Between yellow and red: approx. 1.8 k Ω Increasing to approx. 5.7 k Ω upon actuation

Between yellow and green: approx. 4 k Ω Unchanged upon actuation

Caution: The potentiometer has a nominal value of 4 k Ω \pm 20%. This means:

Due to the 20% tolerance, values may vary between 3.2 k Ω and 4.8 k Ω .

Depending on these tolerances, the measured values may increase or reduce by up to 0.8 k Ω .

9.1.1 Signal Measurement at the Drive Controller (SEVCON)

6. Is connection between A6:X51:3 and A1:X4:3&4 okay? Is battery minus equally connected to A1:X4:3&4?
7. Is battery minus applying at A1:X3:1 after closing of key switch and seat contact switch? Battery minus equally at S54:1? Is connection between A1:X3:1 and S54:1 okay? Only when battery minus is applying to S54 potentiometer switch, the closed direction contactors can control the potentiometer switch and the S53 direction switch.
8. Connection between direction switch and drive controller okay?
S53:B2 to A6-X51:4 (forward)
S53:B4 to A6-X51:5 (reverse)
9. Connection between direction switch and A1 control unit okay?
S53:A2 to A1:X8:4
S53:A4 to A1:X8:2
10. Are 24V applying at A1:X8:4 with “reverse” ride being selected?

9.1.1 Signal Measurement at the Drive Controller (SEVCON)

11. Are 24V applying at A1:X8:2 after “forward” ride selected?
12. Is jumper in A1:X8 between Pin 1 and 3 and 5 okay?
13. Do switches S53 (direction) and S54 (potentiometer) operate faultlessly?
14. Is battery minus applying at A6-X51:4 with “forward” ride being selected (potentiometer switch has to close)?
15. Is battery minus applying at A6-X51:5 with “reverse” ride being selected (potentiometer switch has to close)?
16. Is battery minus no longer applying at A6-X51:11 with “reverse” ride being selected (signal for speed reduction)?

9.1.1 Signal Measurement at the Drive Controller (SEVCON)

17. Is cabling between drive controller and drive motor okay? Please check each cable and their contacts. Do two wires contact via crimping > short-circuit?
18. Do direction contactors switch? Eventually proceed to activate each of them directly.
19. Test with diagnostic device (general diagnostic device and not that specific one for drive controller as in the old version)

9.2 ZAPI Controller

The ZAPI controller has a diagnostic input. Unless not expressly indicated in the service documents, modification of the default values and parameters is **not** admitted.

Contactor arrangement

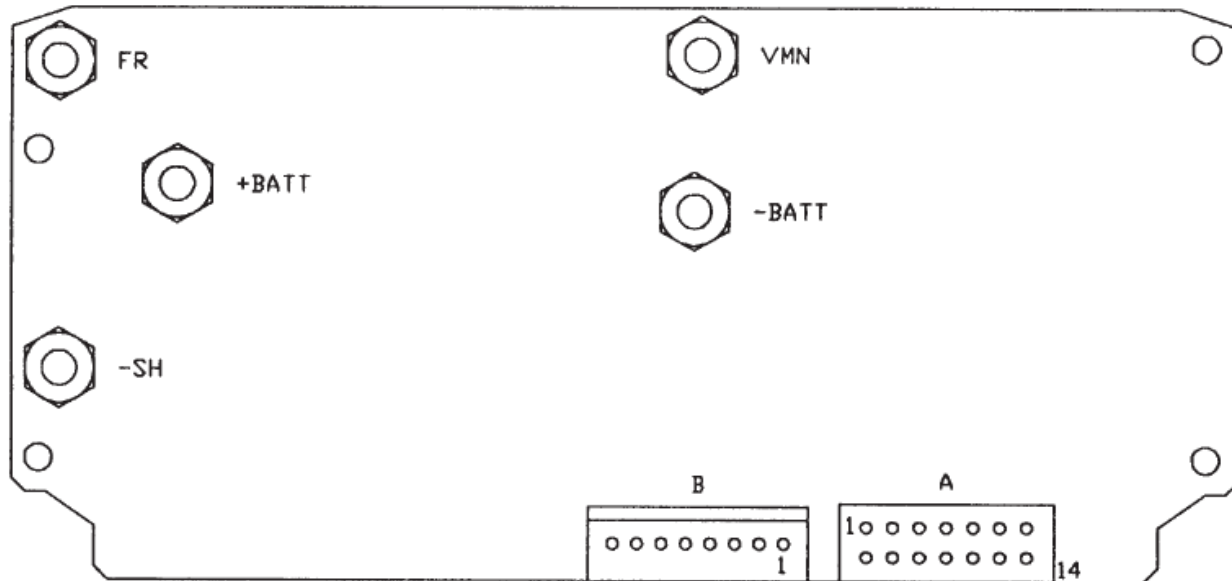

A = Connector for contactor control and control inputs

B = Connector for console or alarm LED

Description of control connections of the ZAPI controller

A1	<i>RV1</i>	Speed reduction 1; active if no positive voltage is applying
A2	<i>IRE</i>	Emergency inversion acc. to Europ. standard; active if a pos. voltage is applying
A3	<i>MT</i>	Tiller micro switch; active if a pos. voltage is applying
A4	<i>NT2</i>	Activation of neg. direction contactor forward ride (auto-stop), Bypass contactor, general contactor or electric brake (standard)
A5	<i>CH</i>	connected + (from key switch)
A6	<i>IRZ</i>	Emergency inversion ("ZAPI standard"); active if no positive voltage is applying
A7	<i>RV2</i>	Speed reduction 2; active if no positive voltage is applying
A8	<i>PT</i>	Activation positive for all contactors and micro-switches
A9	<i>MA</i>	Micro-switch forward ride; active if a pos. voltage is applying
A10	<i>MI</i>	Micro-switch reverse ride; active if a pos. voltage is applying
A11	<i>NT1</i>	Activation negative direction contactor reverse ride (auto-stop) or both direction contactors (standard)
A12	<i>NPOT</i>	Potentiometer negative
A13	<i>CPOT</i>	Potentiometer arm
A14	<i>PPOT</i>	Potentiometer positive (13V; output impedance 82Ohm)

9.2.1 Automatic Monitoring of the Components

The micro-processor effectuates evaluation of basic controller functions.

This evaluation concerns:

- Check upon switching key switch ON:

Watch Dog, current sensor, power MOS FET, contactor activation (contactor driver), direction switch, potentiometer connections, EEPROM)

- Check in standstill:

Watch Dog, current, power MOS FET, contactor activation (contactor driver), potentiometer connections)

- Check during ride:

Watch Dog, current, power MOS FET, contactor activation (contactor driver), potentiometer connections), closing and opening of contactors

- Permanent Monitoring:

Temperature, battery voltage

Eventual error messages are indicated by a blinking LED on connector B (section 2). The number of blinks indicates the error type.

9.2.2 ZAPI Controller

9.2.2 Error Codes Displayed Via The LED

No.	Blinks	Message	State*	Remark
1)	1	WATCH-DOG	A	Error on electronics
2/3/4/5)	1	EEPROM	A	Error on electronics (EEprom)
6)	2	INCORRECT START	B	Direction actuated upon switching ON (or incorrect connection of IR)
7)	3	VMN LOW	B	MOSFET short-circuited
8)	3	VMN HIGH	B	Diodes short-circuited or direction contactor stuck
9)	4	VACC NOT OK	B	Potentiometer defective
10)	5	I=0 EVER	A	No current flow detectable during ride
11)	5	HIGH CURRENT	A	Current flow in rest mode
12)	6	PEDAL WIRE KO	B	Potentiometer wiring defective
13)	7	TEMPERATURE	C	Temperature > 76°C 
15)	8	DRIVER 1 KO	A	NT1 driver short-circuited
16)	8	DRIVER 1 SIC KO	A	Contacteur coil on NT1 short-circuited
17)	8	DRIVER 2 KO	A	NT2 driver short-circuited
18)	8	DRIVER 2 SIC KO	A	Contacteur coil on NT2 short-circuited
19)	8	DRIVER SHORTED	B	Driver short-circuited (NT1)
20)	8	CONTACTOR OPEN	B	Contacteur does not close
21)	9	POSITION HANDLE	B	Tiller micro-switch not actuated
22)	9	INVERSION	B	Deadman bounce key (IR) actuated or incorrectly wired
23)	9	FORW.+BACKW.	B	Both directions simultaneously actuated
24)	Perman. light	BATTERY	C	Battery discharge too important

- *
 A = switch off system, remedy fault and switch on again
 B = remedy fault and actuate direction again
 C = display of state and eventual software-controlled measures

9.2.3 Explanations On Displayed Error Messages

1) WATCH-DOG

Test during rest state as well as during ride; internal self-test of hard- and software; replace controller in case of fault alarm!

2) EEPROM PAR. KO

Error in the memory area containing values of the setting parameters. System switches off. If error still persists after having switched key switch OFF and ON again, replace logic! If error disappears, mind that the saved parameter values are deleted. (—> initial setting)

3) EEPROM CONF. KO

Error in the memory area containing the controller configuration data. If error still persists after having switched key switch OFF and ON again, replace logic! If error disappears, mind that the saved configuration is deleted. (—> initial setting)

4) EEPROM DATA KO

Data of the memory area controlling the hour meter counter are corrupted. If alarm disappears after having switched key switch OFF and ON again, mind that the hour meter counter is reset to zero then.

5) EEPROM OFF LINE

Error in the non-volatile memory containing those values of the hour meter counter concerning the programmable parameters and the saved alarms. If error still persists after having switched key switch OFF and ON again, replace controller!

9.2.3 ZAPI Controller

6) INCORRECT START

Corrupted order of sequence of start conditions. The system only starts if, depending on SAFETY SWITCH programming, the following order is observed :

- Key switch - tiller micro-switch - direction switch (HANDLE)
- Key switch - direction switch (FREE)
- Key switch + seat switch - direction switch (SEAT)

Possible causes:

- a) Direction or tiller micro-switch stuck.
- b) Operator did not observe sequence.
- c) Incorrect wiring.

If no external fault can be detected, replace controller!

9.2.3 ZAPI Controller

7) VMN LOW

Test in rest state and during ride up to VMN synchronised for 80%;

Voltage at VMN terminal normally equals 50% Vbatt if contactors are open. If this voltage is insufficient (< 30% VBatt), an alarm will be output. Possible causes:

- a) Main contactor (if available) does not close or is not connected at all
- b) Short-circuit between VMN and -Batt terminals (metal particle or other)
(disconnect cable at VMN terminal, switch on, fault disappears)
- c) Power MOSFET short-circuited or permanently activated by the logic;
disconnect cable at VMN terminal, switch on, fault persists, replace controller
- d) Bypass contactor (if available) stuck or opens too slowly

9.2.3 ZAPI Controller

8) VMN HIGH

Test in rest state;

Voltage at VMN terminal normally equals 50% Vbatt if contactors are open. If this voltage is excessive (> 70% VBatt), an alarm will be output. Possible causes :

- a) One of the direction contactors is permanently closed due to mechanical blocking or permanent activation (incorrect wiring of contactor coil)
- b) Short-circuit between field and anchor coil of the motor
(disconnect cable at VMN terminal, switch on, Fault disappears, repair motor)
- c) Incorrectly connected motor cable (check field and anchor wiring)
- d) Power element of controller defective (suppressor or brake diodes short-circuited)
disconnect cable from VMN terminal, switch on, fault persists, replace controller

9.2.3 ZAPI Controller

9) VACC NOT OK

Test in rest state;

An alarm is displayed if the potentiometer voltage is higher than 1V, related to the saved minimum value.

Possible causes:

- a) One of the wires at the potentiometer or inductive sensor is broken.
- b) Potentiometer or inductive sensor is defective.

10) I=0 EVER

Test during ride;

If, during ride, the current does not exceed a determined minimum value, the error message appears and the system switches off.

Possible causes :

- a) Resistance of the motor is excessive due to motor defect or faulty carbon brush contact
- b) Current sensor is defective (replace controller)

9.2.3 ZAPI Controller

11) HIGH CURRENT

Test in rest state - contactor open;

If measured current is >50A, an alarm will be output and the system switches off. Current sensor is defective (replace controller!)

12) PEDAL WIRE KO

If no voltage can be measured at the Pin NPOT (A12), to which the negative potentiometer terminal is connected, an alarm is output. Possible causes:

- a) Wire at PPOT (A14) terminal broken
- b) Wire at NPOT (A12) terminal broken
- c) Potentiometer defective (infinite resistance)
- d) Potentiometer resistance >47 k Ohm

9.2.3 ZAPI Controller

13) TEMPERATURE

This message indicates that temperatures has exceeded 76°C.

Maximum current is reduced by steps down to zero with a temperature of 86°C. Possible causes:

- a) If the alarm is output directly after switching the system ON with a cold controller, temperature monitoring is not working correctly (replace controller!)
- b) If the alarm is output shortly after start of operation, heat is insufficiently dissipated (check installation and fastening screws)

14) NO FULL COND.

Test at full speed;

If, at full speed, voltage at the VMN terminal is $> 1/3 V_{\text{Batt}}$, this is an indication for a faulty diagnostic circuit and the system switches off.

If the error persists, replace controller (logic unit).

9.2.3 ZAPI Controller

15) DRIVER 1 KO

If voltage at the NT1 terminal (A11) does not correspond to the desired value, an alarm is output and the system switches off.

Possible causes:

- a) Wire at the NT1 terminal (A11) broken or coil of the direction contactor for reverse ride is defective.
- b) Internal driver MOSFET short-circuited (replace controller!)

16) DRIVER 1 SIC KO

If current load at the contactor driver which activates the NT1 output (A11) is excessive, an alarm is output and the system switches off.

Possible causes :

- a) Short-circuit of the wire at NT1 terminal (A11) to +Batt
- b) Coil of the connected contactor short-circuited or current consumption > 5A

9.2.3 ZAPI Controller

17) DRIVER 2 KO

If voltage at the NT2 terminal (A4) does not correspond to the desired value, an alarm is output and the system switches off.

Possible causes:

- a) Wire at the NT2 terminal (A4) broken or coil of the direction contactor for forward ride is defective.
- b) Internal driver MOSFET short-circuited (replace controller!)

18) DRIVER 2 SIC KO

If current load at the contactor driver which activates the NT2 output (A4) is excessive, an alarm is output and the system switches off.

Possible causes :

- a) Short-circuit of the wire at NT2 terminal (A4) to +Batt
- b) Coil of the connected contactor short-circuited or current consumption > 5A

9.2.3 ZAPI Controller

19) DRIVER SHORTED (only with H0 STANDARD TRACT.)

If voltage at the NT1 terminal (A11) does not correspond to the desired value, an alarm is output and the system switches off.

Possible causes:

- a) Wire at the NT1 terminal (A11) broken or coil of the direction contactor for forward or reverse ride is defective.
- b) Internal driver MOSFET short-circuited (replace controller!)

20) CONTACTOR OPEN

Test upon actuation of a direction;

- It is checked whether the selected direction contactor closes by measuring the value of the VMN. If this value is not correct, an alarm is output.

Proceed to the following instructions for remedy:

9.2.3 ZAPI Controller

When does error occur?	1st test	result	2nd test	Result	Error
In forward direction only	Forward direction contactor closes for 0.3 seconds and then opens	Yes	-->	-->	A1
		No	For 0.3 seconds, a voltage applies to the coil of the forward direction contactor	Yes	B1
				No	C1
In reverse direction only	Reverse direction contactor closes for 0.3 seconds and then opens	Yes	-->	-->	A2
		No	For 0.3 seconds, a voltage applies to the coil of the reverse direction contactor	Yes	B2
				No	C2
In both directions	Forward or reverse direction contactor (as actuated) closes for 0.3 seconds and then opens	Yes	-->	-->	A3
		No	For 0.3 seconds, a voltage applies to the coil of the forward or reverse direction contactor (as actuated)	Yes	B3
				No	C3

9.2.3 ZAPI Controller

- A1** The NO contact of the forward direction contactor (TA) or the NC contact of the reverse direction contactor (TI) is soiled or stuck.
Clean contacts or replace contactor group if required.

Clean NO contact of the forward
direction contactor (TA)

Schließer-Kontakt des
Fahrtrichtungsschütz
vorwärts (TA) reinigen.

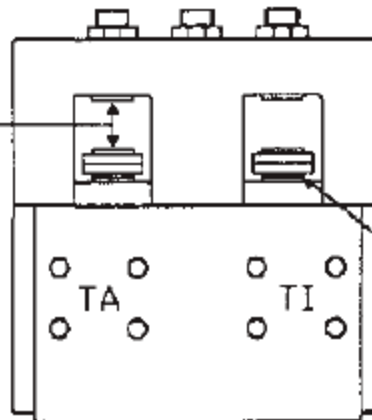

Clean NC contact of the reverse
direction contactor (TI)

Öffner-Kontakt des
Fahrtrichtungsschütz
rückwärts (TI) reinigen.

9.2.3 ZAPI Controller

- A2** The NC contact of the forward direction contactor (TA) or the NO contact of the reverse direction contactor (TI) is soiled or stuck.
Clean contacts or replace contactor group if required.

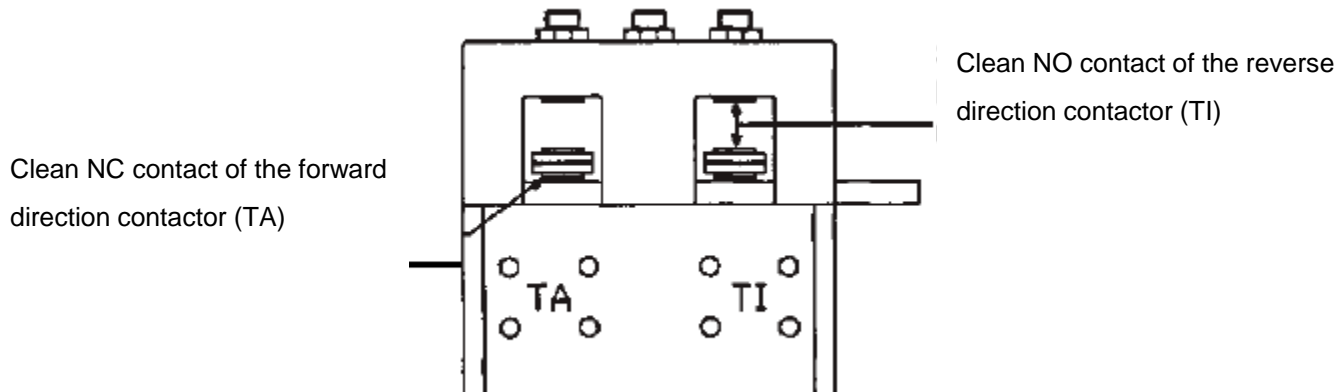

9.2.3 ZAPI Controller

A3

Connection to motor interrupted:

- Carbon brushes without contact to collector (Fig. 1)
- Connecting cable of carbon brush broken (Fig. 2)
- Motor winding defective or motor cable broken
- Inverted motor connection

Fig. 1

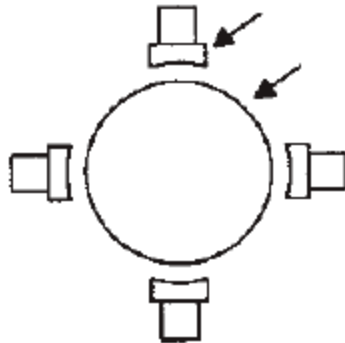
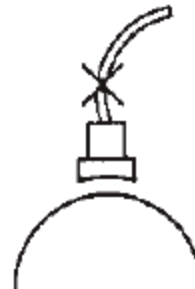

Fig. 2



9.2.3 ZAPI Controller

- B1** The forward direction contactor is correctly activated but does not close.
- contactor coil defective, measure resistance by ohmmeter
 - contact is mechanically blocked
 - nominal voltage of contactor coil is higher than the battery voltage
- B2** The reverse direction contactor is correctly activated but does not close.
- contactor coil defective, measure resistance by ohmmeter
 - contact is mechanically blocked
 - nominal voltage of contactor coil is higher than the battery voltage
- B3** The forward or reverse direction contactor is correctly activated but does not close.
- coils of contactors are defective, measure resistance by ohmmeter
 - contacts are mechanically blocked
 - nominal voltage of contactor coils is higher than the battery voltage
- C1** No voltage at the coil of the forward direction contactor. Check connector and cable of the contactor coil to plus supply and to Pin A4 (NT2).
- C2** No voltage at the coil of the reverse direction contactor. Check connector and cable of the contactor coil to plus supply and to Pin A11 (NT1).
- C3** No voltage at the coils of the forward and reverse direction contactors. Check connectors and cables of the contactor coils to plus supply and to Pin A4 (NT2) and A11 (NT1).
- Are the items C1, C2, C3 without fault, replace logic.

21) POSITION HANDLE

If, upon switching ON, the tiller micro-switch has already been actuated, an error is output (only if SAFETY SWITCH is programmed to HANDLE). Possible causes:

- a) Tiller micro-switch stuck
- b) Incorrect operation

22) INVERSION

If, upon switching ON, the emergency inversion switch (deadman) has been pressed, an alarm is output. Possible causes:

- a) Micro-switch for emergency inversion stuck
- b) Incorrect operation
- c) Incorrect wiring or programming

23) FORW - BACK

Fault is displayed if two directions are simultaneously active. Possible causes:

- a) Wiring defective.
- b) Direction micro-switch stuck. If none of the causes applies, replace logic!

24) BATTERY

Battery discharged, i.e. voltage has fallen below 60% of nominal voltage. An alarm is output. The system switches off but may be restarted. In that case, maximum current will be reduced to 50% of the programmed maximum current value.

9.3 Drive Motor B1050 (Amer)

9.3.1 Tyre replacement

Unscrew the 4 screws of the hub

Warning! Lift up the machine so that the tyre is not touching the ground

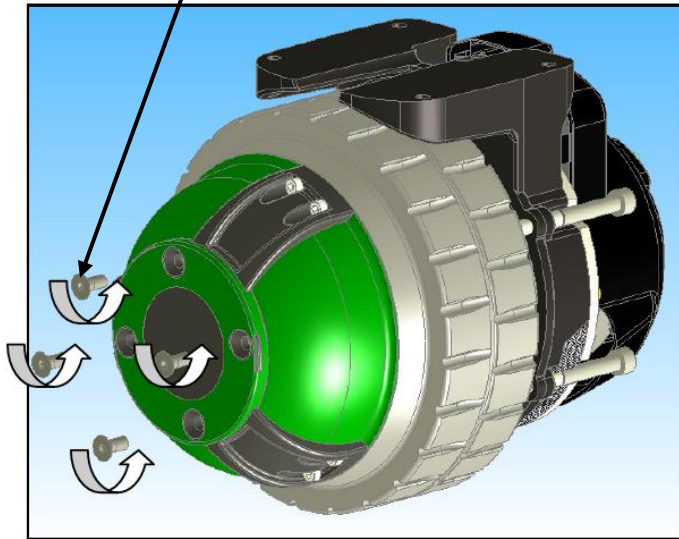

Screw the 4 pullers two by two (at 180°) in the bracket until the hub is removed (Tool PN 03502210)

Warning! Remove the 4 pullers after this operation

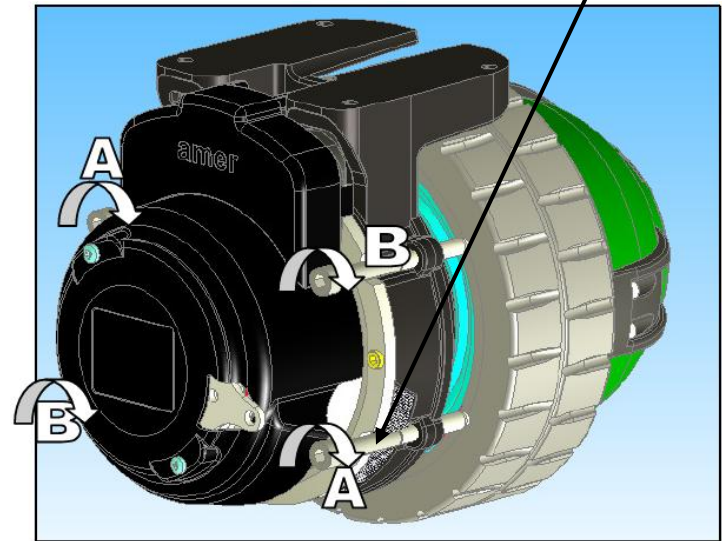

9.3 Drive Motor B1050 (Amer) **PowerBoss**[®] The Power of Clean

Remove the plastic hub cover

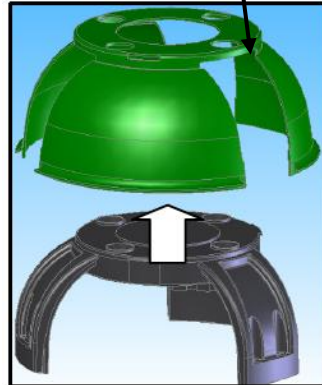

Unscrew the 6 screws M6x30
tightening torque 16Nm \pm 10%

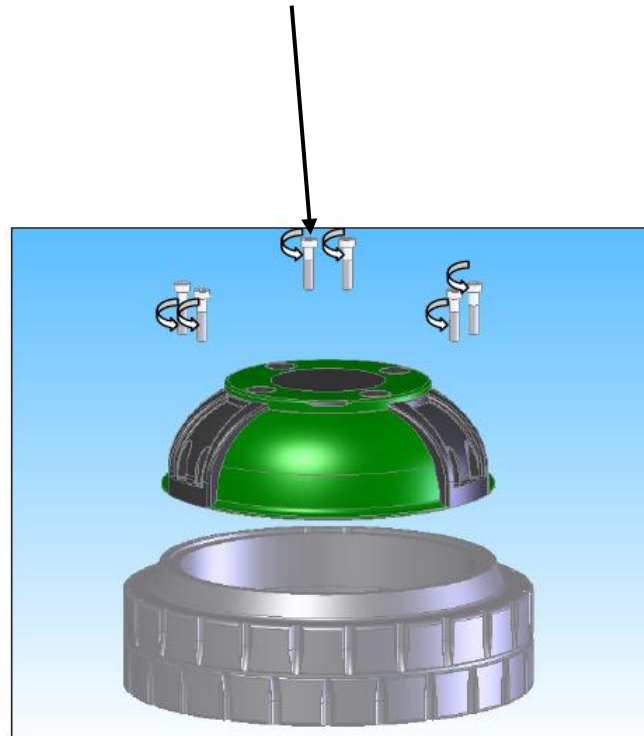

Replace the old tyre and re-assemble
the new tyre with the hub without the
plastic hub cover
Torque screw 16 Nm \pm 10%

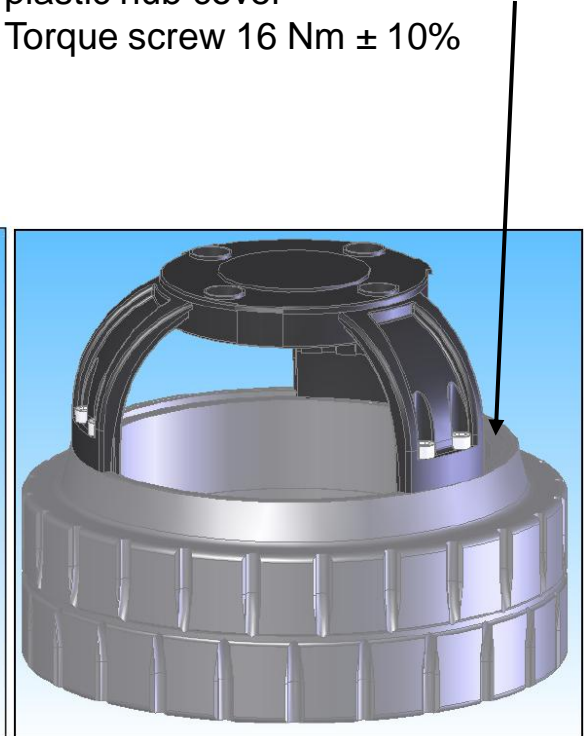

9.3 Drive Motor B1050 (Amer)

PowerBoss[®]
The Power of Clean

Warning! Check the radial position of the hub with the inner disc during the mounting

Tire puller kit (Tool PN 03502210)

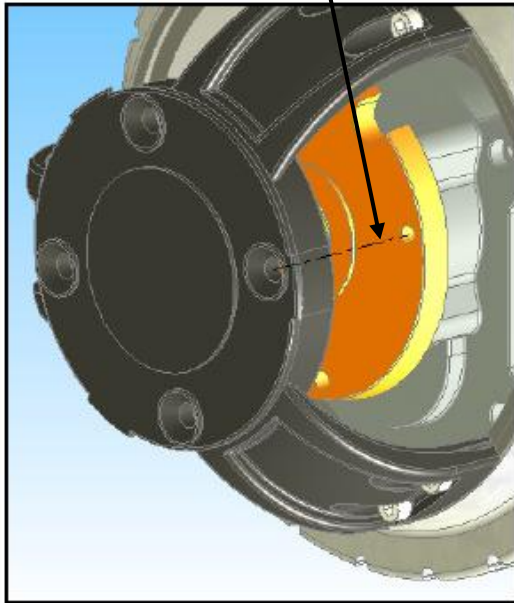

Install the wheel on the MTR11 by using a plastic mallet

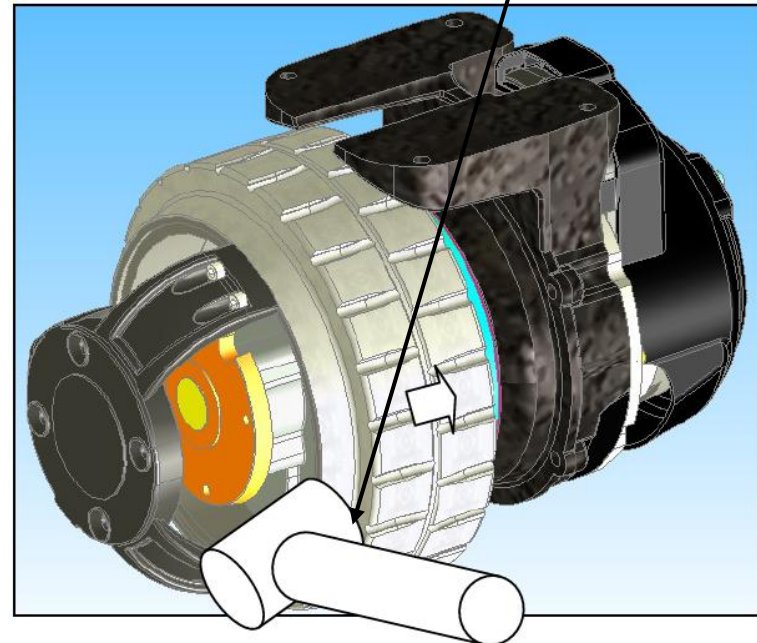

9.3 Drive Motor B1050 (Amer) **PowerBoss**[®] The Power of Clean

Screw the 4 screws M8x20
tightening torque screw 22 Nm \pm 10%

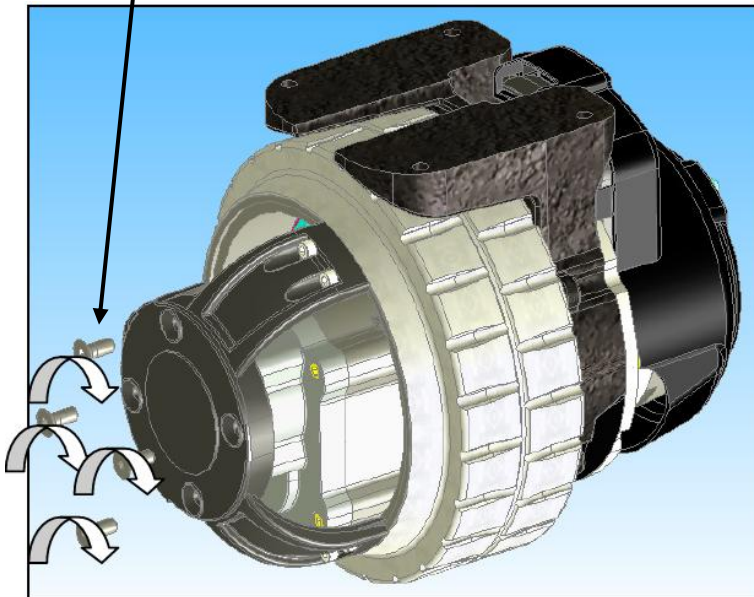

Mount the plastic cover hub manually

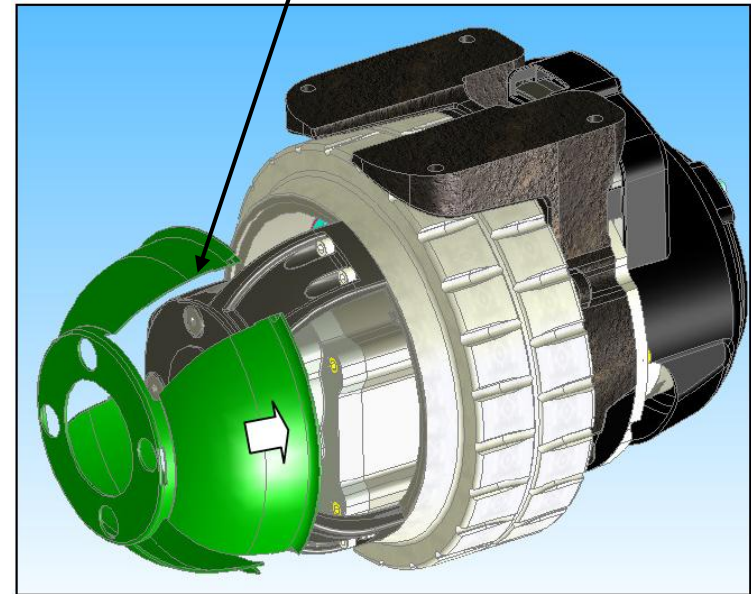

9.3.2 Drive Motor B1050 (Amer) **PowerBoss**[®] The Power of Clean

Check (every 1000 hours) and replacement (max. 1500 hours) of the carbon brushes

•the wear out limit of the carbon brushes is 12 mm

Unscrew the 2 nuts.
After remove the terminal board cover.

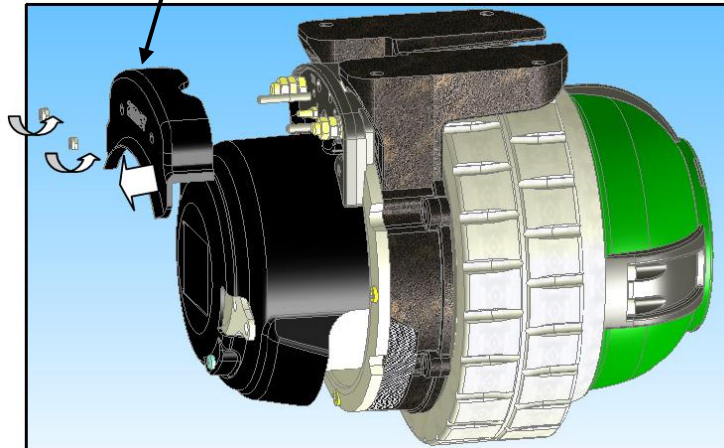

Remove the 4 screws M6x20.
tightening torque 9.5Nm -10% +20%
Then remove the motor.
Replace the carbon brushes.

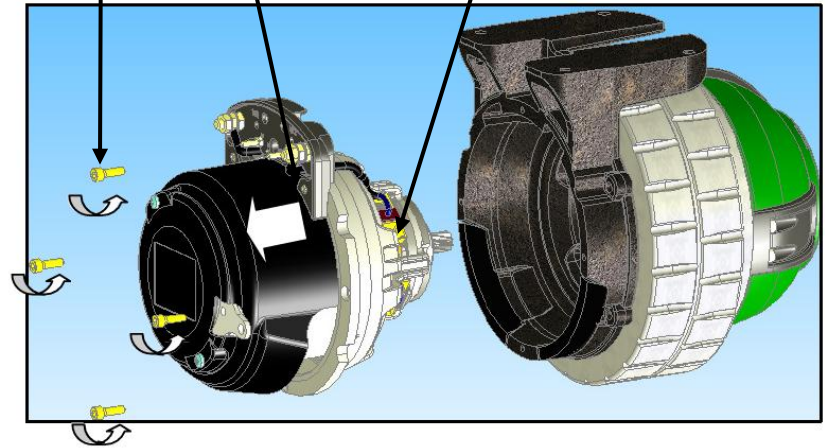

9.3.3 Diagnostic LED for Drive control unit (Italsea)

Display / <i>Flashes</i>	Alarm	What To Do
Alarm A1 FORWARD switch ON	Forward switch closed at power-on	Put the speed reference to zero and open the Forward switch
Alarm A2 BACHWARD switch ON	Backward switch closed at power on	Put the speed reference to zero and open the Backward switch
Alarm A3 Potentiometer Fault	Potentiometer fault	Check the potentiometer and it's wiring
Alarm A4 Reference OUT of neutral	Potentiometer out of neutral position at power-on	Move the potentiometer to neutral position or if it is in neutral position yet, calibrate the speed reference.
Alarm A5 Over temperature	Thermal protection	Wait a few minutes and check the motor current
Alarm A6 POWER STAGE	Controllers power stage damaged	replace the controller
Alarm A7 OVERCURRENT	Over-current: short circuit	Check the motor's wires: if ok, and the controller repeats this alarm, replace the controller
Alarm A8 Power fuse/Relais	Power fuse or main contactor damaged	Controller detects a failure on the external power fuse or power connections. If controller repeats this alarm and the power connections are ok, replace it

9.3.3 Diagnostic LED for Drive control unit (Italsea)

Display / <i>Flashes</i>	Alarm	What To Do
Alarm A9 Undervoltage	Undervoltage	Check battery charging level
Alarm A10 Overvoltage	Overvoltage	Battery voltage higher than 45V: check the battery
Alarm A11 Overload Current	Overload protection (armature or field)	Check the Motor working current Armature: I_{max} 50A Field: I_{max} 12A
Alarm A12 Disable ON	Disable switch ON	Check the input switch: this alarm will reset by power-off. Input voltage at -A6:J2.6
Alarm A13 KEY-OFF	Key-Off sequence detected	Check the key switch connections. Input voltage at -A6:J2.15
Alarm A14 E2PROM FAIL	E2PROM fail	Check the settings: if the controller repeats this alarm, replace it.
Alarm A15 Field Fault		Check the field output connections / wirings. If ok replace controller
Alarm A16 Forward and Backward switch on	Both direction switches on	Check the direction switches and / or their connections

10. Error Table With Information **PowerBoss**[®] On Service Display *The Power of Clean*

Error code in the display	Malfunction	Remark
1.2.5.2.	Thermal switch Brush motor 1); 2); 3); 4); 5)	Wire broken since NC activation? Measure operating current (approx. 12 A for a motor when operated without increased pressure and on Fama Famin) Motor overload due to unfavourable floor-brush-combination and/or permanent ride with increased ground pressure?
1.2.5.5.	Thermal switch 3rd Brush motor (Modul3 Code C) 4) ; 5)	Wire broken since NC activation? Measure operating current (approx. 12 A for a motor when operated without increased pressure and on Fama Famin) Motor overload due to unfavourable floor-brush-combination and/or permanent ride with increased ground pressure?

10. Error Table With Information **PowerBoss**[®] On Service Display

The Power of Clean

Error code in the display	Malfunction	Remark
1.2.6.1.	Blocking protection Brush motor (right and left) 1); 2); 3); 4); 5)	Check 35 A fuse Measure operating current (approx. 12 A for a motor when operated without increased pressure and on Fama Famin) Motor overload due to unfavourable floor-brush-combination and/or permanent ride with increased ground pressure?
1.2.6.2.	Blocking protection 3rd Brush motor (Modul3 Code C) 4); 5)	Check 35 A fuse Measure operating current (approx. 12 A for a motor when operated without increased pressure and on Fama Famin) Motor overload due to unfavourable floor-brush-combination and/or permanent ride with increased ground pressure?

10. Error Table With Information **PowerBoss**[®] On Service Display

The Power of Clean

Error code in the display	Malfunction	Remark
1.2.6.3.	Electronic circuit-breaker Brush lifting element 1); 2); 3); 4); 5)	Jammed? Lifting element stopped by limit stop before being switched off by micro-switch? Check coding of Module 1 Measure operating current (approx. 3.5A max. during lifting)
1.3.5.1.	Thermal switch Side brush 1); 2)	Jammed? Permanent contact to border during ride? Wire broken since NC activation? Check 35 A fuse; Measure operating current (approx. 8 A max.)
1.3.6.1.	Blocking protection Side brush 1); 2)	Jammed? Permanent contact to border during ride? Wire broken since NC activation? Check 35 A fuse; Measure operating current (approx. 8 A max.)

10. Error Table With Information **PowerBoss**[®] On Service Display

The Power of Clean

Error code in the display	Malfunction	Remark
1.3.6.2.	Blocking protection Lifting element Side brush 1); 2)	Jammed? Lifting element stopped by limit stop before being switched off by micro-switch? Check coding of Module 3 Code D Measure operating current (approx. 1.2A max. during lifting)
1.4.6.1.	Electronic circuit-breaker Lifting element Squeegee 1); 2); 3); 4); 5)	Jammed? Lifting element stopped by limit stop before being switched off by micro-switch? Check coding of Module 1 Measure operating current (approx. 3.2A max. during lifting)

10. Error Table With Information **PowerBoss**[®] On Service Display

The Power of Clean

Error code in the display	Malfunction	Remark
2.2.5.1.	Thermal switch Broom (and thermal switch Side brush Motor if new version is fitted) 1); 5)	Thermal switch of Broom or Side brush motor opened or cabling faulty? Jammed? Measure operating current (approx. 9.5 A max. on Fama Famin for broom motor) Wrong sweeping track width? Unfavourable floor-brush-combination? At machines equipped with the new side brush version (Kit 105-736, side brush motor PN 105-733): Is side brush setting okay? Jammed? Measure operating voltage (max. 2.5 A after approx. 10 minutes run) and approx. 100-110 rpm

10. Error Table With Information **PowerBoss**[®] On Service Display *The Power of Clean*

Error code in the display	Malfunction	Remark
2.2.6.1.	Blocking protection broom 1); 5)	Jammed? Check 35 A fuse Measure operating current (approx. 9.5 A on Fama Famin floor), Sweeping track adjustment (30 mm - 50 mm) Unfavourable floor-broom combination?
2.2.6.2.	Blocking protection lifting element broom 1); 5)	Jammed? Does lifting element moves up to dead stop before being switched off by micro switch? Check module coding module 3 Code A switch S4 to OFF Measure operating current (approx. 3.3 A when lifting)

10. Error Table With Information **PowerBoss**[®] On Service Display

The Power of Clean

Error code in the display	Malfunction	Remark
2.3.5.1.	Thermal switch side broom left / right (1); 3); 5)	Side broom setting okay? Jammed? Measure operating current (max. 2.5 A after approx. 10 minutes run)
2.3.6.1.	Blocking protection L-h side broom (1); 3); 5)	Side broom setting okay? Jammed? Measure operating current (max. 2.5 A after approx. 10 minutes run) and approx. 100-110 rpm
2.3.6.2.	Blocking protection R-h side broom (1); 3); 5)	Side broom setting okay? Jammed? Measure operating current (max. 2.5 A after approx. 10 minutes run) and approx. 100-110 rpm

10. Error Table With Information **PowerBoss**[®] On Service Display *The Power of Clean*

Error code in the display	Malfunction	Remark
2.3.6.4.	Blocking protection lifting element side broom 3)	Jammed? Does lifting element moves up to dead stop before being switched off by micro switch?
3.1.6.1.	Fuse Module 1 1); 2); 3); 4); 5)	Check 10 A / 80 V fuse. If code for blocking protection of lifting element for brush or squeegee is indicated, check these, check water pump; with SWA equally check K2 and water pump (SWA) check 35A fuse; measure operating current of suction turbines (approx. 19.5 A max. for one Motor)

10. Error Table With Information On Service Display

Error code in the display	Malfunction	Remark
3.1.6.2.	Fuse Module 3 Code A (for pre-sweeper) 1); 3); 5)	<p>Check all fuses F1(10 A / 80 V) and F4-F7, check motors for filter suction (F6 = 20A/80V), shaking (F7 = 20A/80V), r-h (F4) and l-h side broom (F5)</p> <p>Caution: If old version of side broom motor (PN 51-237) is still installed, the F4 and F5 fuses are 20A/80V. If new version of side brush motor (PN 105-733) is already installed, the F4 and F5 fuses are 10A/80V</p>

10. Error Table With Information **PowerBoss**[®] On Service Display *The Power of Clean*

Error code in the display	Malfunction	Remark
3.1.6.5.	Fuse Module 3 Code C (for 3rd brush) 4); 5)	Check all fuses F1(10 A / 80 V) and F4-F7 (5A/80V)

10. Error Table With Information **PowerBoss**[®] On Service Display *The Power of Clean*

Error code in the display	Malfunction	Remark
3.1.6.6.	Fuse Module 3 Code D (for side brush) 1); 2)	Check all fuses (F4 - F7 (5 A / 80 V)) and F1 (10 A / 80 V), check water valve Side brush
3.1.6.7.	Fuse Control electronic 1); 2); 3); 4); 5)	Check fuse 7.5 A / 32 V Check connection to cleaning agent unit (A7:X2:2), to Module 1 (A5:X1) and to the Modules 3 (A4:X1 and A9:X1) and to the operator panel cleaning agent/SWA (A10:X1:1) for abrasion, short-circuit, etc.

10. Error Table With Information **PowerBoss**[®] On Service Display *The Power of Clean*

Error code in the display	Malfunction	Remark
3.2.1.1.	TSG defective 1); 2); 3); 4); 5)	Measure approximate battery voltage on control electronics A1.X2 PIN 1 and 4 even with the machine being switched off; if not okay, check cable connection up to battery plug; check battery selection setting of Dip switch on control electronics; if okay but error 3.2.1.1 still present, then replace control electronics (also see chapter 3.4)
3.4.1.1.	Accelerator fault 1); 2); 3); 4); 5)	Check accelerator and direction switch as well as cabling

10. Error Table With Information **PowerBoss**[®] On Service Display *The Power of Clean*

Error code in the display	Malfunction	Remark
3.4.5.1.	Thermal switch of drive motor 1); 2); 3); 4); 5)	Is travel drive smooth? Parking brake setting okay? Longer uphill rides effectuated? Interrupted wire since NC activation? Measure operating current (approx. 40 A during cleaning)
4.1.2.1.	Module 1 not recognised 1); 2); 3); 4); 5)	Check fuse F1 (2 A / 32 V), check water valve of brushes and SWA; check contacts and contactors; check current supply of Module 1 (voltage transformer) check CAN connectivity

10. Error Table With Information **PowerBoss**[®] On Service Display *The Power of Clean*

Error code in the display	Malfunction	Remark
4.1.3.1.	Module 1 no response (timeout) 1); 2); 3); 4); 5)	Check fuse F1 (2 A / 32 V); check CAN bus; check contacts and connectors; check resistance (2 x 120 Ω) check current supply of Module 1 (voltage transformer)
4.3.2.1.	Module 3 Code A not recognised (for pre-sweeper) 1); 3); 5)	CAN bus connected? Check fuse F3 (2 A / 32 V); check contacts and connectors; module coding okay? (see chapter 6.2) check current supply of Module 3 (voltage transformer)

10. Error Table With Information **PowerBoss**[®] On Service Display *The Power of Clean*

Error code in the display	Malfunction	Remark
4.3.2.3.	Module 3 Code C not recognised (for 3rd brush) 4); 5)	CAN bus connected? Check fuse F3 (2 A / 32 V); check contacts and connectors; module coding okay? (see chapter 6.2) check current supply of Module 3 (voltage transformer)
4.3.2.4.	Module 3 Code D not recognised (for side brush) 1); 2)	CAN bus connected? Check fuse F3 (2 A / 32 V); check contacts and connectors; module coding okay? (see chapter 6.2) check current supply of Module 3 (voltage transformer)

10. Error Table With Information On Service Display

Error code in the display	Malfunction	Remark
4.3.3.1.	Module 3 Code A no response; timeout (for pre-sweeper) 1); 3); 5)	CAN bus connected? Check fuse F3 (2 A / 32 V); check contacts and connectors; module coding okay? (see chapter 6.2) check current supply of Module 3 (voltage transformer)
4.3.3.3.	Module 3 Code A no response; timeout (for pre-sweeper) 4); 5)	CAN bus connected? Check fuse F3 (2 A / 32 V); check contacts and connectors; module coding okay? (see chapter 6.2) check current supply of Module 3 (voltage transformer)

10. Error Table With Information **PowerBoss**[®] On Service Display

The Power of Clean

Error code in the display	Malfunction	Remark
4.3.3.4.	Module 3 Code D no response; timeout (for side brush) 1); 2)	CAN bus connected? Check fuse F3 (2 A / 32 V); check contacts and connectors; module coding okay? (see chapter 6.2) check current supply of Module 3 (voltage transformer)
4.5.2.1.	CAN operator panel Code A not recognised (for pre-sweeper/side brush) 1); 5)	Check CAN bus to operator panel pre-sweeper/side brush; check contacts and connectors; check resistance (120 Ω); check module coding (see chapter 7) (60 Ω due to parallel connection)

10. Error Table With Information **PowerBoss**[®] On Service Display

The Power of Clean

Error code in the display	Malfunction	Remark
4.5.2.2.	CAN operator panel Code B not recognised (for Cleaning agent/SWA) 1); 5)	Check CAN bus to Cleaning agent/SWA operator panel; check contacts and connectors; check resistance (120 Ω); check module coding (see chapter 7) (60 Ω due to parallel connection)
4.5.3.1.	CAN operator panel Code A no response; timeout (for pre-sweeper / side brush) 1); 5)	Check CAN bus to pre-sweeper/side brush operator panel; check contacts and connectors; check resistance (120 Ω); check voltage supply of operator panel (voltage transformer) (60 Ω due to parallel connection)

10. Error Table With Information **PowerBoss**[®] On Service Display *The Power of Clean*

Error code in the display	Malfunction	Remark
4.5.3.2.	CAN operator panel Code B no response; timeout (for Cleaning agent / SWA) 1); 5)	Check CAN bus to Cleaning agent/SWA operator panel; check contacts and connectors; check resistance (120 Ω); (60 Ω due to parallel connection) Check voltage supply of operator panel (voltage transformer)
4.6.1.1.	Internal control unit error 1); 2); 3); 4); 5)	Check contacts of all connectors on control electronics (for corrosion); check voltage supply (current transformer) replace control electronics

10. Error Table With Information **PowerBoss**[®] On Service Display *The Power of Clean*

Error code in the display	Malfunction	Remark
4.6.2.1.	CAN bus error (no response - timeout) 1); 2); 3); 4); 5)	Check CAN bus cabling between control electronics and modules; check contacts and connectors; check resistance (120 Ω) (60 Ω due to parallel connection)
4.6.3.1.	CAN bus error (Buserror) 1); 2); 3); 4); 5)	Check CAN bus cabling between control electronics and modules; check contacts and connectors; check resistance (120 Ω) (60 Ω due to parallel connection)
4.6.3.2.	CAN bus error (overrun) 1); 2); 3); 4); 5)	Check CAN bus cabling between control electronics and modules; check contacts and connectors; check resistance (120 Ω) (60 Ω due to parallel connection)

10. Error Table With Information **PowerBoss**[®] On Service Display *The Power of Clean*

Error code in the display	Malfunction	Remark
4.6.5.1.	Wrong machine type set 1); 2); 3); 4); 5)	Check machine setting of Dip switch A on control electronics A1
4.6.5.2.	Set option not available 1); 2); 3); 4); 5)	Too many options set on Dip switch B (see chapter 3)? All modules connected via CAN bus?

10. Error Table With Information **PowerBoss**[®] On Service Display

The Power of Clean

Error code in the display	Malfunction	Remark
4.6.5.3.	Module overhang (too many modules in the machine) 1); 2); 3); 4); 5)	All options set on Dip switch B (see chapter 3)?

- 1) - Hakomatic B1100
- 2) - Hakomatic B 1050 TB
- 3) - Hakomatic B 1050 WZB
- 4) - Hakomatic B 1050 TB 1230
- 4) - Hakomatic B 1100 TB 1230

Current values for cleaning units always depend on the condition of broom and brushes as well as on the type of floor.

11. Notes

12. Brooms, Brushes, & Blades

ADM

38C Brushes And Side Brooms

7887	Cylindrical Brush Light (2 Required)
7846	Cylindrical Brush Medium (Standard) (2 Required)
7890	Cylindrical Brush Heavy (2 Required)
7848	Cylindrical Brush Very Heavy(2 Required)
7847	Cylindrical Brush Extremely Heavy(2 Required)
6348	Standard Side Sweeping Broom(2 required)

ADM 40 Brushes

7592	Pad Driver
7587	Disc Brush Light Duty (2 Required)
7589	Disc Brush Light Medium Duty (2 Required)
7588	Disc Brush Medium Duty (2 Required) (Standard)
7325	Disc Brush Medium Heavy Duty (2 Required)
7590	Disc Brush Heavy Duty (2 Required)
7591	Disc Brush Heavy Extreme Duty (2 Required)

ADM 40 Brooms (Pre Sweep Option)

00980330	Main Broom
6237.00	Side Broom

ADM 38 Squeegees and Side Blade

107-709	Front Squeegee blade Linatex
107-710	Rear Squeegee blade Linatex
00411620	Front Squeegee blade Poly
00411580	Rear Squeegee blade Poly
107-425	Side Squeegee (2 Required)

ADM 40 Squeegees

107-709	Front Squeegee Blade Linatex
107-710	Rear Squeegee Blade Linatex
00411620	Front Gum Rubber Blade (standard) (Gray)
00411580	Rear Gum Rubber Blade (standard) (Gray)
00975320	Side Squeegee (2 Required) (pre June 2011)
01271180	Side Squeegee (2 Required) (post June 2011)